

i550 / i850 / i950

Service Manual

Revision 0

Canon

QY8-1385-000

COPYRIGHT © 2002 CANON INC. CANON i550/i850/i950 0902 GR

Scope

This manual has been issued by Canon Inc. to provide the service technicians of this product with the information necessary for qualified persons to learn technical theory, maintenance, and repair of products. This manual covers information applicable in all localities where this product is sold. For this reason, this manual may contain information that is not applicable to your locality.

Revision

This manual could include technical inaccuracies or typographical errors due to improvements or changes made to this product. When changes are made to the contents of this manual, Canon will release technical information as the need arises. When substantial changes are made to the contents of this manual over a long or short period, Canon will issue a revised edition of this manual.

The following do not apply if they do not conform to the laws or regulations of the country where this manual or product is used.

Trademarks

Product and brand names appearing in this manual are registered trademarks or trademarks of the respective holders.

Copyright

All rights reserved. No part of this manual may be reproduced in any form or by any means or translated into another language without the written permission of Canon Inc., except in the case of internal business use.

Copyright © 2002 by Canon Inc.

CANON INC.

i Printer Technical Support Dept. 11, 21

16-1, Shimonoge 3-chome, Takatsu-ku, Kawasaki, Kanagawa 213-8512, Japan

I. Manual Outline

This manual is divided into the following three parts to provide information necessary to service the i550, i850, and i950.

Part 1: Maintenance

This part describes information necessary for troubleshooting the i550, i850, and i950.

Part 2: Technical Reference

This part provides description of new technologies, etc., used in the i550, i850, and i950.

Part 3: Appendix

This part contains block diagrams, pin layouts, and product specification lists.

Reference

This manual does not provide sufficient information for disassembly and assembly. Refer to the figures in the separate parts catalogue.

II. Table of Contents

Page	Part 1: Maintenance
1 - 1	1. Periodic Replacement/Periodic Inspection/Life
1 - 2	2. Troubleshooting List by Error/Symptom
1 - 5	3. Repair Details
1 - 5	3.1 Precautions
1 - 5	3.1.1 Precautions regarding ink stains
1 - 5	3.1.2 Precautions when releasing the carriage lock
1 - 5	3.1.3 Precautions when removing/installing tap screws
1 - 5	3.1.4 Code strip handling precautions
1 - 6	3.1.5 Do not loosen or remove red screws
1 - 6	3.1.6 Logic board removal precautions
1 - 7	3.2 Adjustments
1 - 7	3.2.1 Waste ink counter setting
1 - 7	3.2.2 Resetting EEPROM
1 - 8	3.2.3 Applying grease (oil)
1 - 9	3.3 Settings
1 - 9	3.3.1 Standalone printer operation
1 - 9	3.3.2 Service mode functions
1 - 11	3.3.3 Test print sample
1 - 14	3.3.4 Printing EEPROM information
1 - 15	3.4 Verification
1 - 15	4. Printer Transportation Method

Page	Part 2: Technical Reference
2 - 1	1. New Technologies
2 - 2	2. Cleaning Mode and Suction Amount
2 - 3	3. Print Mode List
2 - 6	4. FAQ

Page	Part 3: Appendix
3 - 1	1. Block Diagram
3 - 3	2. Connector Locations and Pin Layout
3 - 3	2.1 i550 Connector Locations and Pin Layout
3 - 8	2.2 i850 Connector Locations and Pin Layout
3 - 12	2.3 i950 Connector Locations and Pin Layout
3 - 16	2.4 Product Specification List

Part 1
Maintenance

1. Periodic Replacement/Periodic Inspection/Life

<Periodic replacement>

Level	Periodic replacement
User	None
Service personnel	None

<Periodic inspection>

Level	Periodic inspection
User	None
Service personnel	None

<Life>

(1) Paper feed count:

- Main body -

<i550 / i850>

30,000 sheets (monochrome, 1,500 character standard text pattern printing)

10,000 sheets (printing each color at 7.5% duty)

<i950>

10,000 sheets (Pattern printing each color at 7.5% duty)

(2) 5 years

The life of this product is (1) or (2) above, which ever comes first.

- Print head life -

<i550 / i850>

30,000 sheets: monochrome printing (1,500 character standard text pattern printing)

10,000 sheets: color printing (pattern printing each color at 7.5% duty)

<i950>

9,000 sheets: Pattern printing each color at 7.5% duty (BK, Y, M, C) : 5,000 sheets

1,500 character standard pattern printing (BK) : 2,000 sheets

Photo image (6 colors) : 2,000 sheets

<Serial number location>

Carriage ribbon cable holder (visible when access cover is opened)

2. Troubleshooting List by Error/Symptom

Table 1-1 Operator Call Errors

Error codes are displayed on the monitor of the connected computer.

Start the status monitor on the host computer in order to display the error codes.

Orange Flash (Error Code)	Error description	Action	Assembly/disassembly precautions	Adjustment
2 (1000)	No paper error	Set paper and press the Resume key		
3 (1300)	Paper jam error	Remove paper and press the Resume key	- Be careful that spurs do not come off when removing paper	
4 (1601,1611, 1612,1613 1634* ¹ ,1635* ¹)	No ink error	Replace and set ink tank(s)	- Be careful of ink stains	
6 (1401)	No cartridge error	Install head or replace head/logic board/carriage	- Be careful of ink stains - Be careful of electrostatic damage	- Set waste ink counter (see 3.2.1)* ¹ - Set destination (see 3.3.2)
7 (1403,1405 1485* ¹)	Cartridge error	Replace head/carriage/logic board	- Be careful of ink stains - Be careful of electrostatic damage	- Set waste ink counter (see 3.2.1)* ¹ - Set destination (see 3.3.2)
8 (1700)	Waste ink full warning	Replace waste ink absorber	- Be careful of ink stains - Be careful of electrostatic damage	- Clear EEPROM (see 3.2.2)

*¹: i950 only

Table 1-2 Service Call Errors

Error messages are displayed on the monitor of the connected computer.

Start the status monitor on the host computer in order to display the error messages.

Cyclical flash (Error Code)	Error description	Action	Assembly/disassembly precautions	Adjustment
2 (5100)	CR error	Replace code strip/carriage unit/logic board	<ul style="list-style-type: none"> - Be careful of electrostatic damage - Do not loosen or remove red screws - There must be no grease on code strip 	<ul style="list-style-type: none"> - Apply grease (see 3.2.3) - Set waste ink counter (see 3.2.1)*² - Set destination (see 3.3.2)
3 (6000)	LF error	Replace code wheel/LF encoder unit/logic board	<ul style="list-style-type: none"> - Be careful of electrostatic damage - Do not loosen or remove red screws - There must be no grease on code strip 	<ul style="list-style-type: none"> - Apply grease (see 3.2.3) - Set waste ink counter (see 3.2.1)*² - Set destination (see 3.3.2)
4 (5C00)	Recovery system error	Replace purge unit/logic board	<ul style="list-style-type: none"> - Be careful of ink stains - Be careful of electrostatic damage 	<ul style="list-style-type: none"> - Set waste ink counter (see 3.2.1)*² - Set destination (see 3.3.2)
6 (5400)	Internal temperature error * ¹	Replace logic board	<ul style="list-style-type: none"> - Be careful of electrostatic damage 	<ul style="list-style-type: none"> - Set waste ink counter (see 3.2.1)*² - Set destination (see 3.3.2)
7 (5B00)	Waste ink full error	Replace waste ink absorber/logic board	<ul style="list-style-type: none"> - Be careful of ink stains - Be careful of electrostatic damage - Do not loosen or remove red screws 	<ul style="list-style-type: none"> - Clear EEPROM (see 3.2.2) - Set waste ink counter (see 3.2.1)*² - Set destination (see 3.3.2)
8 (5200)	Head overheating error	Replace head/logic board	<ul style="list-style-type: none"> - Be careful of ink stains - Be careful of electrostatic damage 	<ul style="list-style-type: none"> - Set waste ink counter (see 3.2.1)*² - Set destination (see 3.3.2)
9 (6800)	EEPROM error	Replace logic board	<ul style="list-style-type: none"> - Be careful of electrostatic damage 	<ul style="list-style-type: none"> - Set waste ink counter (see 3.2.1)*² - Set destination (see 3.3.2)
10 (6100)	ROM error * ²	Replace logic board	<ul style="list-style-type: none"> - Be careful of electrostatic damage 	<ul style="list-style-type: none"> - Set waste ink counter (see 3.2.1)*² - Set destination (see 3.3.2)
11 (6300)	RAM error * ²	Replace logic board	<ul style="list-style-type: none"> - Be careful of electrostatic damage 	<ul style="list-style-type: none"> - Set waste ink counter (see 3.2.1)*² - Set destination (see 3.3.2)
13	Other hardware error * ²	Replace head/logic board	<ul style="list-style-type: none"> - Be careful of ink stains - Be careful of electrostatic damage 	<ul style="list-style-type: none"> - Set waste ink counter (see 3.2.1)*² - Set destination (see 3.3.2)
LED ON* ¹ (6800)	RAM error	Replace logic board	<ul style="list-style-type: none"> - Be careful of electrostatic damage 	<ul style="list-style-type: none"> - Set waste ink counter (see 3.2.1)*² - Set destination (see 3.3.2)

*¹: i550/i850 only *²: i950 only

Table 1-3 Troubleshooting by Symptom

Symptom	Action	Assembly/disassembly precautions	Adjustment	
Operation error	Does not power on Power goes off immediately after power on	Replace AC adapter/logic board	- Be careful of electrostatic damage	
	Head not recognized Does not return to home position	Remove/install print head or replace print head/carriage unit	- Be careful of ink stains - Do not loosen or remove red screws - There must be no grease on code strip	
	Abnormal noise	Remove debris/correct loose parts		
	Printing stops before completing	Replace logic board	- Be careful of electrostatic damage	
Feed error	Multiple sheets are fed together	Replace ASF		
	Paper does not feed	Remove debris/replace ASF	- Be careful that spurs do not come off	
	Paper skews	Remove debris/adjust paper guide position		
	Does not print at all/no color	Replace print head/ink tank/logic board/purge unit	- Be careful of ink stains - Be careful of electrostatic damage	
Print result error	Scratches or white streaks appear even after cleaning Lines not in data printed	Remove/install print head or replace print head/ink tank/purge unit/carriage unit	- Be careful of ink stains - Do not loosen or remove red screws - There must be no grease on code strip	
	Paper is soiled	Pass few sheets of paper/clean paper path with cloth or replace platen absorber/purge unit	- Be careful of ink stains	
	Spur tracks appear	Replace platen unit	- Be careful not to bend spur tips	
	Missing lines	Replace ink tank/head	- Be careful of ink stains	
	Bad coloring	Replace print head	- Be careful of ink stains	
	Printing overlapped	Replace platen unit		
	Black ink not ejected	Refresh print head/replace print head	- Be careful of ink stains	
	Figures/characters stretched	Clean grease on code strip or replace carriage unit	- Do not loosen or remove red screws - There must be no grease on code strip	
				- Set waste ink counter (see 3.2.1)*1 - Set destination (see 3.3.2)
				- Set waste ink counter (see 3.2.1)*1 - Set destination (see 3.3.2)
				- Set waste ink counter (see 3.2.1)*1 - Set destination (see 3.3.2)

*1: i950 only

3. Repair Details

3.1 Precautions

3.1.1 Precautions regarding ink stains

Be careful not to touch the ink path and stain the printer, work bench, hand, or clothes with ink during repair.

3.1.2 Precautions when releasing the carriage lock

The carriage locks at the capping position when the power is turned off normally, with the cartridge installed in the carriage.

If the printer does not operate normally, manually release the carriage lock as necessary.

Turn the gear in the figure in the direction of the arrow to release the carriage lock.

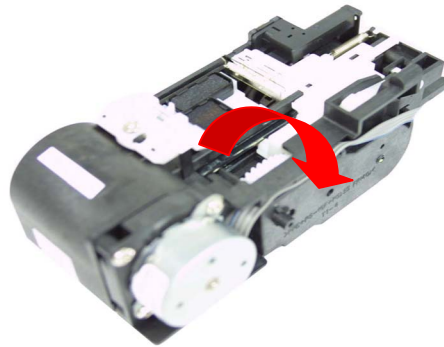

Figure 1-1 Releasing Carriage Lock

3.1.3 Precautions when removing/installing tap screws

Tap screws are used to secure the printer unit and the base. When a tap screw is removed, mold scrap may adhere to the screw threads, which can damage the mold-side threads when the tap-screw is re-fastened. Therefore, remove the mold scraps adhered to the screw or use a new screw when re-installing.

3.1.4 Code strip handling precautions

- 1) Do not apply grease to the code strip.

If grease contacts the code strip, the code strip slits may become unreadable, causing errors.

If grease contacts the code strip, wipe off thoroughly with alcohol.

- 2) Do not bend or scratch the code strip.

Replace the code strip if it is scratched, or bent until it is white.

- 3) Extend the leaf spring when attaching or removing the code strip.

The code strip is held taut and secured by the leaf spring.

Note that if the spring is stretched too far in the direction of the arrow, it will not properly re-secure the code strip.

Be careful not to pull too hard on the code strip when installing or removing it.

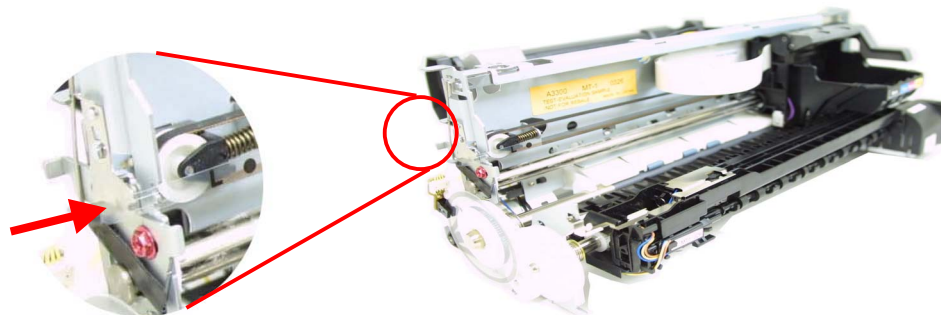

Figure 1-2 Code Strip

3.1.5 Do not loosen or remove red screws

Do not loosen or remove the red screws below because they cannot be adjusted in the field.

(a) Head gap adjustment red screw x 2 (one on each side)

(b) Paper feed motor anchor screw x 2

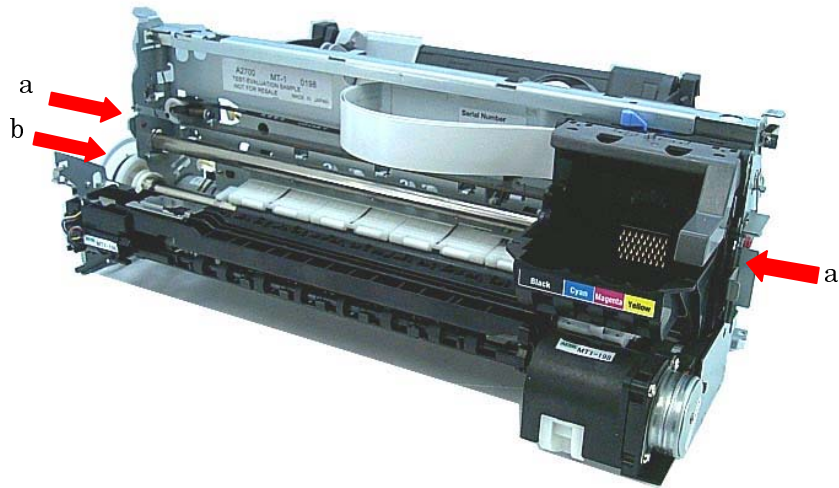

Figure 1-3 Do Not Loosen or Remove Red Screws

3.1.6 Logic board removal precautions

The Logic Board can be damaged due to short circuiting during removal.

When removing the Logic Board, unplug the power cord and allow the unit to sit for approximately 1 minute to discharge the capacitor.

3.2 Adjustments

3.2.1 Waste ink counter setting

(1) When replacing the logic board, replace the waste ink absorber, depending on the value of the waste ink counter.

Use the following table as a guide to replacement.

Table 1-4 Waste Ink Absorber Replacement Timing and Waste Ink Counter Setting

Waste ink counter setting	i550 / i850 / i950
0 - 7	Clear waste ink counter
7 - 100	Clear waste ink counter and replace waste ink absorber

Print the EEPROM information in service mode to check the waste ink count.

(2) PIXUS 950i waste ink counter clearing method

After selecting the waste ink counter setting via the service mode function (for details, refer to 3.3.2), press the Power button. Then, without pressing the Resume button, press the Power button once again.

3.2.2 Resetting EEPROM

When the EEPROM is reset, the entire contents of the EEPROM is cleared (excluding the following items).

<i550 / i850>

- USB-S/N
- Waste ink counter

<i950>

- USB-S/N

3.2.3 Applying grease (oil)

After disassembly/assembly, apply special tool grease at the locations shown below.
Apply a thin layer of grease using a flat brush.

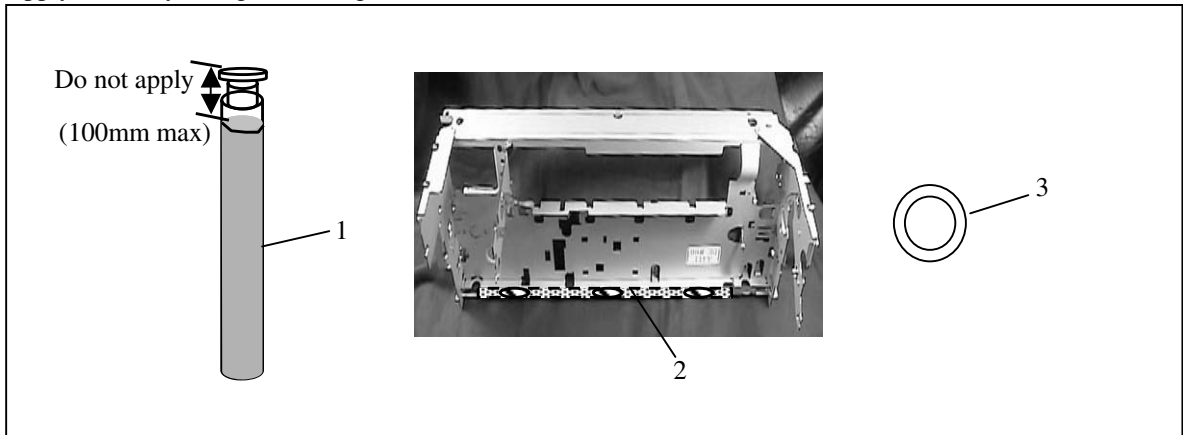

Figure 1-4 Applying Grease

i550 / i850

Location	Grease/Oil name	Amount
1. Carriage shaft circumference	Floil KG107A	200 - 400mg
2. CR slider, selector lever sliding surface	Floil KG107A	27.5±7.5 mg

i950

Location	Grease/Oil name	Amount
1. Carriage shaft circumference	EU-1	80±30 mg
2. CR slider, selector lever sliding surface	Floil KG107A	27.5±7.5 mg
3. Carriage oil pad* ¹	EU-1	100±10 mg

3.3 Settings

3.3.1 Standalone printer operation

This printer has an offline mode which allows the printer operation without connection to a computer.

With the printer powered ON, press and hold the Resume button until the green indicator flashes the specified number of times to start each operation, and then release the Resume button to execute the function.

LED flash	Operation	Remark
1	Cleaning	
2	Nozzle check pattern print	Set A4 size or larger paper and print
3	Roller cleaning	Clean without paper and then clean with paper (A4 or larger) set

3.3.2 Service mode functions

This printer has a Service mode to set service only settings and output test prints. The Service mode can be entered using the control panel.

<Service mode operation list>

- 1) With the printer power OFF, while pressing the Resume button, press the Power button. (Do not release the power button.)
- 2) While pressing the Power button, release the Resume button, press the Resume button again twice, and then release the Resume button and Power button.
- 3) The green indicator flashes during initialization.
When the indicator stops flashing and remains on, press the Resume button the specified number of times to select the function.
(The indicator toggles between orange and green each time the Resume button is pressed.)
- 4) After selecting the function, press the Power button, and the green indicator will light, and the function will be executed.

<i550/i850 Service Mode>

Count	LED	Function	Remark
0	Green	Power off	When there is no head, the carriage returns to the home position and locks
1	Orange	Service test print	
2	Green	EEPROM information print	
3	Orange	EEPROM initialization	Destination is set to overseas during EEPROM initialization
4	Green	Clear waste ink counter	Clear waste ink counter
5	Orange	Destination setting	After selecting a function press the Resume button (1: Overseas, 2: Domestic)
6	Green	Head refreshing	Clean both BK/CL ink
7	Orange		Not used for service
8	Green		Not used for service
9	Orange		Not used for service
10	Green	Return to selection menu	

<i950 Service Mode>

Count	LED	Function	Remark
0	Green	Power off	When there is no head, the carriage returns to the home position and locks
1	Orange	Service test print	
2	Green	EEPROM information print	
3	Orange	EEPROM initialization	Destination becomes overseas during EEPROM initialization
4	Green	Waste ink counter setting	Clear waste ink counter (see 3.2.1 Waste ink counter setting)
5	Orange	Destination setting	After selecting a function press the Resume button (0: Domestic, 1: Overseas)
6	Green	Default registration adjustment pattern	Not used for service
7	Orange	Default registration adjustment setting	Not used for service
8	Green	Roller cleaning	ASF paper feed roller cleaning (rotate ASF 10 times)
9	Orange		Not used for service
10	Green		Not used for service
11	Orange		Not used for service
12	Green	LF check pattern	Not used for service
13	Orange	Return to selection menu	

(Press the Power button to cancel during printing)

3.3.3 Test print sample

(1) i550

Test print sample

i550 V0.43 D=000.9 CH=0000 ERO=1000 Bk=04937 C=02179 M=02164 Y=02167
ST=2002/06/19-13:59 PC(M=0002 R=0001 T=0000 D=0000 C=0000) PWC(S=00003 h=00002)
EADG=0000 PAGE(ALL=00035 PP=00032 HR=00003 GP=00000 PC=00000 OTHER=00000)

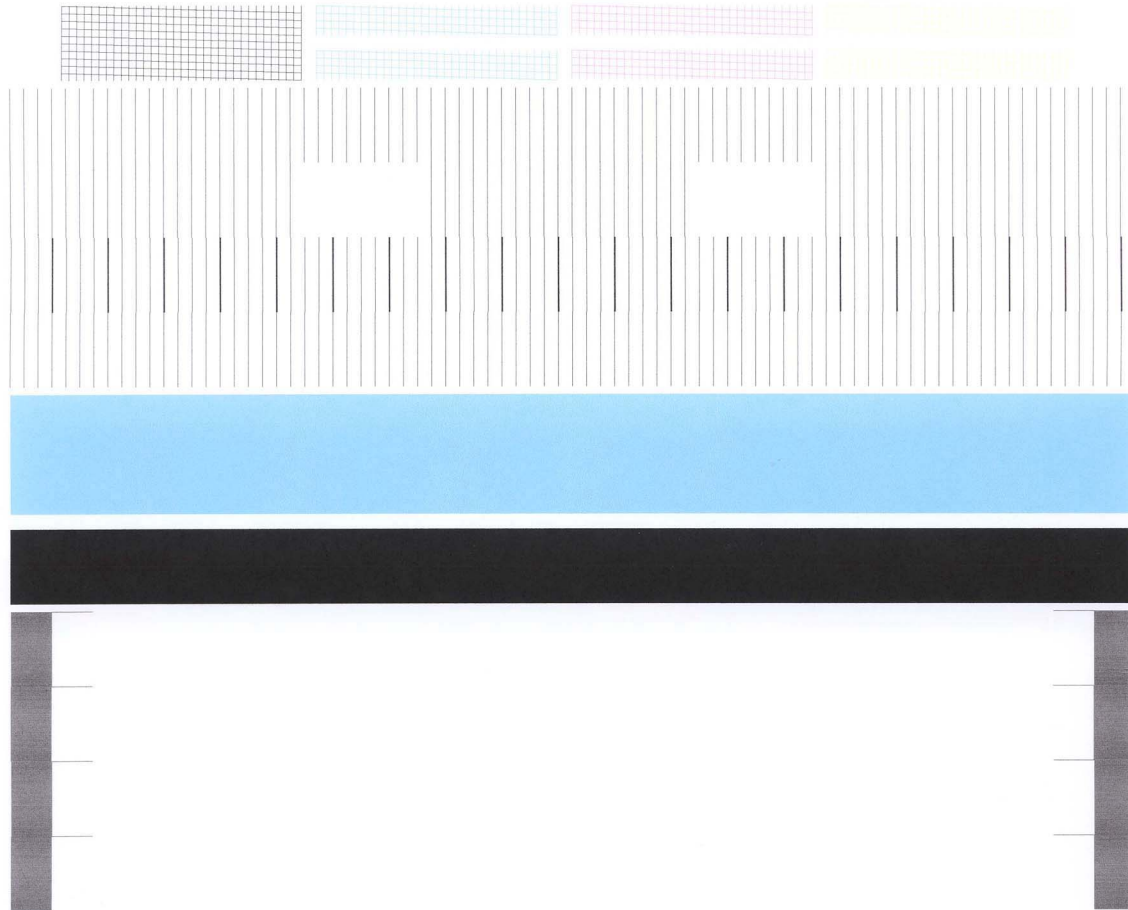

Figure 1-5 Service Test Print Sample (i550)

(1) i850

Test print sample

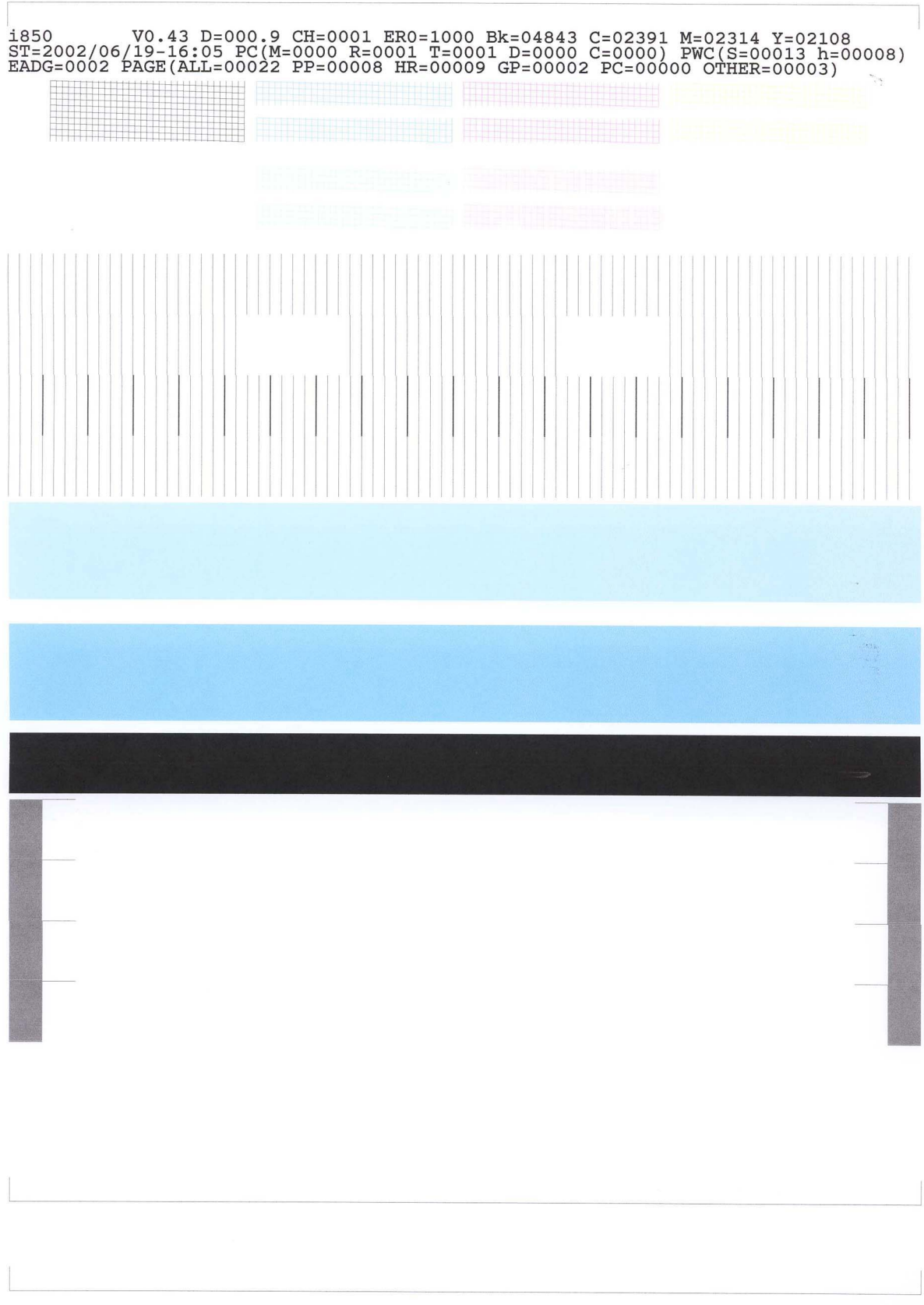

Figure 1-6 Service Test Print Sample (i850)

(1) i950

Test print sample



Figure 1-7 Service Test Print Sample (i950)

3.3.4 Printing EEPROM information

EEPROM print prints the content of the printer internal EEPROM and the EEPROM in the print head.

The resulting output can be used to check the printer settings and data.

<i550 / i850>

[Print Example]

```
i550 V0.01 D=000.0 Page=00000 CH=00000 Bk(00) Cl(+2)
Head TempBk=18.5 Head TempC=17.5 Env Temp=30.0 FF(3F 3F 3F)
PC(M=0000 R=0000 T=0000 D=0000 C=0000) Bk=00000 C=00000 M=00000 Y=00000
WP=0000 IC(BK=0 C=0 M=1 Y=0) CT(BK=00000 Y=00000 M=00000 C=00000)
USB=(BCDEFG) ER(TIME=2002/00/00-00:00 ER0=1000 ER1=5100 ER2=5200 ER3=1000)
UR(C=000 BK=000 BK-C=+02 Y=000 M=000 G=+01 H=-01) CDR=(-00005,-000029) *1
ST=2002/00/00-00:00 PWC(S=00000 h=00000) CN(USB=1 1284=0) EDGE=00000
PAGE(ALL=00000 PP=00000 HR=00000 GP=00000 MP=00000 SP=00000 PC=00000 OTHER=00000)
```

[Print Item Name]

1: Model 2: ROM version 3: Waste ink capacity 4: Print count 5: Head installation count 6: Bidirectional registration (black, color) 7: Head temperature (black, color) 8: Internal temperature 9: Process inspection information 10: Recovery operation count (MRTDC) 11: Dot count (Bk, C, M, Y) 12: Wipe count 13: Ink (Yes=0, No=1) 14: Ink removal/installation count (Bk, Y, M, C) 15: USB serial (6 characters) 16: Operator call/service call log (time, log 0.1.2.3) 17: User registration adjustment value: odd↔even (C↔C, Bk↔Bk, Bk↔C, Y↔Y, M↔Ye, G, H) 18: CDR compensation*¹ 19: Installed date 20: Power on count (hard/soft) 21: Connection I/F (USB1284) 22: Borderless printing count 23: Paper pass count (all, plain paper, high resolution paper, glossy photo paper, matte photo paper, photo paper plus glossy, post card, others)

*¹ Not used because it is for PIXUS 850i Japanese model only

<i950>

[Print Example]

```
i950 V0.01 S/N(000000) BK(-1) D=000.00% FA=3F 3F 3F CDR(000,000) *1
CH=0000 CT(C=0000 CL=0000 K=0000 Y=0000 ML=0000 M=0000)
Page=0000 ED(00000/00000/00000) OE(00000/00000) CD=00000*1
SV(0000/0000) OP(0000/0000/0000)
UR(Ce=+01 Co=-01 CLe=+01 CLo=+01 Ke=+01 Ko=+01 Ye=+01 Yo=+01)
(MLe=+10 MLo=+10 Me=+10 Mo=+10)
DIR((C=000 LC=000 K=000 Y=000 ML=000 M=000)
PT=2002/06/11-10:30 ST=2002/06/11 LP=2002/06/11 PD=0 IF=0 0 AP=000
DC(C=000 CL=000 K=000 Y=000 ML=000 M=000)
PC(5D=00000 DC=00000 MN=00000 20D=000 RF=000 SH=000) OT=000
```

[Print Item Name]

1: Model 2: ROM version 3: Serial no. 4: Bidirectional registration 5: Waste ink capacity 6: Process inspection information 7: CDR compensation*¹ 8: Head installation count 9: Ink removal/installation count (C, CL, K, Y, ML, M) 10: Total paper pass count 11: Paper pass count (normal/special/post card) 12: No border paper pass count (post card/other) 13: CDR paper pass count*¹ 14: Service call log (log 0.1) 15: Operator call log (log 0.1.2) 16: User registration adjustment value (Ce, Co, Cle, Clo, Ke, Ko, Ye, Yo) 17: User registration adjustment value (Mle, MLo, Me, Mo) 18: Bidirectional registration (C, LC, K, Y, ML, M) 19: Last suction time 20: Installed time 21: Last suction date 22: Page delay 23: USB connection log (1.1/2.0) 24: Auto power on 25: Dot count (C, CL, K, Y, ML, M) 26: Suction count (5 day timer/dot count/manual/20 day timer/refresh/shipment suction/cap open)

*¹ Not used - reserved for PIXUS 950i Japanese model only

3.4 Verification

- (1) Print the nozzle check pattern when replacing the print head, sheet feeder unit, purge unit, or carriage unit.
- (2) Check the connection with PC and print the nozzle check pattern when replacing the PCB.

4. Printer Transportation Method

This section describes the procedures for transporting the printer (for example, when returning after repair).

- (1) Keep the print head in the carriage.
- (2) Turn off the power and ensure that it is properly capped at home position.



If the print head is left alone by itself, the ink may solidify.

Therefore, keep the print head (with ink tank) in the carriage even when transporting.

Also, secure the carriage at home position to prevent it from moving and applying stress to the encoder film during transportation.



If the print head must be transported by itself, perform the following:

1. Install ink tanks for each color. (to prevent nozzles from drying)
2. Install the orange protective cap on the print head.
(to prevent damage to the print head due to shock etc.)

Part 2

Technical Reference

1. New Technologies

ASF features

- Retard separation method
- Stacking limit: 150 sheets (SK paper)
- Stacking height: 13mm
- Paper feed roller diameter: $\phi 20$ round roller (through axis type)
- Separation roller diameter: $\phi 14$
- Separation roller retracts after paper feed
- Return claw structure
- Reduced noise
- Reduced paper curl
- Reduced double feed

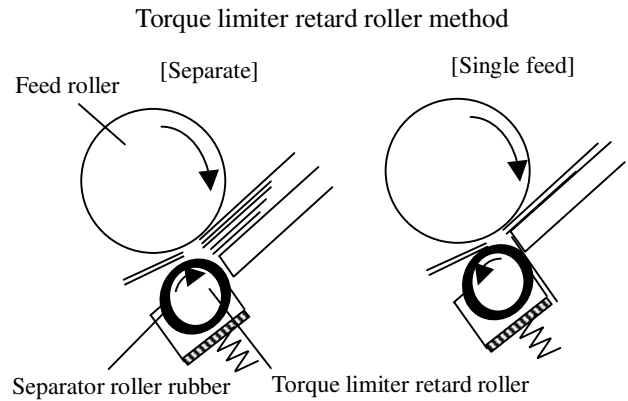

- May skew easily, as the pickup roller is only on one side.
- The sheet feeder unit pressure plate is easily deformed during storage because the pressure plate spring is only on one side.
- Separation roller rubber wears easily.

2. Cleaning Mode and Suction Amount

Print head cleaning is performed effectively and efficiently depending on conditions in order to prevent print errors caused by bubble, dust, or ink clogging.

Cleaning is performed before starting to print except at the following timing:

- Dot count suction: Performed after paper ejection
- Manual cleaning/refreshing: Performed during operation
- Unit delivery: Performed when access cover is closed

Table 2-1 Cleaning Mode List (i550/i850)

Condition	Details	Suction amount BK/CL (g)
Manual cleaning	Panel operation and printer driver operation	0.14/0.36
Refreshing	Printer driver operation	1.58/0.72
Timer suction	If 24 to 336 hours have elapsed since previous suction (BK). If 120 to 336 hours have elapsed since previous suction.	0.14/0.36
Long timer suction I	If 336 hours or more have elapsed since previous suction.	0.45/0.72
Long timer suction II	If 1080 hours or more have elapsed since previous suction.	0.78/0.72
Long timer suction III	If 2160 hours or more have elapsed since previous suction.	1.58/0.72
Long timer suction IV	If 4320 hours or more have elapsed since previous suction.	1.58/0.72
Dot count suction	When prescribed dot count since the last suction is reached	0.14/0.36
When replacing print head	When print head is removed/installed	0.45/1.08
When replacing ink tank	Ink sensor detects that ink is present in the ink tank →That is the state changed from no ink in the ink tank	1.58/0.72
At delivery or during first head position adjustment	Suction when head is first installed after factory shipment	0.45/1.08
Uncapped when Soft ON	When capping was not performed properly during last power off	0.30/0.72

Table 2-2 Cleaning Mode List (i950)

Condition	Details	Suction amount BK/CL (g)
Manual cleaning	Panel operation and printer driver operation	0.89
Refreshing	Printer driver operation	2.68
120 hour timer suction	If 120 to 480 hours have elapsed since previous suction.	0.89
480 hour timer suction	If 480 hours or more have elapsed since previous suction.	1.34
Dot count suction	When prescribed dot count since the last suction is reached	1.1
When replacing print head	When print head is removed/installed	2.68
When replacing ink tank	Ink sensor detects that ink is present in the ink tank →That is the state changed from no ink in the ink tank	1.34
At delivery	Suction when head is first installed after factory shipment	2.68
Uncapped when Soft ON	When capping was not performed properly during last power off	2.68
After hardware power ON (If time is not checked)	Standalone test print etc.	1.34
Cap open (When cap has been open for 30 minutes or more)	When uncapped for more than 30 minutes during printing or in standby	0.89

*¹ Suction amount is the total for 6 colors

3. Print Mode List

Table 2-3 Print Mode List (i550)

Paper type		Quality 5	Quality 4	Quality 3	Quality 2	Quality 1
Plain paper	Passes Pig/YMC Resolution Print quality	1 pass Pig 300x300 Fast	1, 2 passes Pig 600x600 Standard	1, 4 passes Pig 600x600 ---	4 passes Pig 600x600 High	
High resolution paper HR-101S	Passes Pig/YMC Resolution Print quality		2 passes YMC CM:1200x1200 Y:600x600 ---	4 passes YMC 1200x1200 Standard	6 passes YMC 1200x1200 High	
Photo paper pro PR-101	Passes Pig/YMC Resolution Print quality				4 passes YMC 1200x1200 Standard	6 passes YMC 1200x1200 High
Glossy photo paper GP-301	Passes Pig/YMC Resolution Print quality			4 passes YMC 1200x1200 Standard	6 passes YMC 1200x1200 High	12 passes YMC 2400x1200 ---
Ink jet Post card Envelope	Passes Pig/YMC Resolution Print quality		2 passes YMC CM:1200x1200 BKY:600x600 Standard	4 passes YMC 1200x1200 High		
Post card	Passes Pig/YMC Resolution Print quality		3 passes Pig+YMC CM:1200x1200 BKY:600x600 Standard	6 passes Pig+YMC BK: 600x600 CL:1200x1200 High		
Glossy film HG-201	Passes Pig/YMC Resolution Print quality				4 passes YMC 1200x1200 Standard	6 passes YMC 1200x1200 High
T shirt transfer paper TR-201	Passes Pig/YMC Resolution Print quality			6 passes YMC 1200x1200 High		
OHP film CF-102	Passes Pig/YMC Resolution Print quality			4 passes Pig+YMC BK:600x600 CL:1200x1200 Standard	6 passes Pig+YMC BK:600x600 CL:1200x1200 High	
Matte photo paper MP-101	Passes Pig/YMC Resolution Print quality			4 passes YMC 1200x1200 Standard	6 passes YMC 1200x1200 High	
Photo paper plus glossy PP-101	Passes Pig/YMC Resolution Print quality				4 passes YMC 1200x1200 Standard	6 passes YMC 1200x1200 High

* Bold items are default settings

Table 2-4 Print Mode List (i850)

Paper type		Quality 5	Quality 4	Quality 3	Quality 2	Quality 1
Plain paper	Passes Pig/YMC Resolution Print quality	1 pass Pig 600x600 Fast	1 pass Pig 600x600 Standard	1, 4 passes Pig 600x600 - - -	4 passes Pig 600x600 High	
High resolution paper HR-101S	Passes Pig/YMC Resolution Print quality		2 passes YMC 600x600 - - -	4 passes YMC 1200x1200 Standard	6 passes YMC 1200x1200 High	
Photo paper pro PR-101	Passes Pig/YMC Resolution Print quality			4 passes YMC 1200x1200 Standard	6 passes YMC 1200x1200 High	16 passes YMC 4800x1200 - - -
Glossy photo paper GP-301	Passes Pig/YMC Resolution Print quality			4 passes YMC 1200x1200 Standard	6 passes YMC 1200x1200 High	12 passes YMC 2400x1200 - - -
Ink jet Post card	Passes Pig/YMC Resolution Print quality		2 passes YMC BK:600x600 CL:600x600 Standard	4 passes YMC BK:600x600 CL:1200x1200 High		
Post card	Passes Pig/YMC Resolution Print quality		3 passes Pig+YMC BK:600x600 CL:600x600 Standard	4 passes Pig+YMC BK:600x600 CL:1200x1200 High		
Glossy film HG-201	Passes Pig/YMC Resolution Print quality			4 passes YMC 1200x1200 Standard	6 passes YMC 1200x1200 High	
T shirt transfer paper TR-201	Passes Pig/YMC Resolution Print quality			6 passes YMC 1200x1200 High		
OHP film CF-102	Passes Pig/YMC Resolution Print quality			4 passes Pig+YMC BK:600x600 CL:1200x1200 Standard	6 passes Pig+YMC BK:600x600 CL:1200x1200 High	
Matte photo paper MP-101	Passes Pig/YMC Resolution Print quality			4 passes YMC 1200x1200 Standard	6 passes YMC 1200x1200 High	
Photo paper plus glossy PP-101	Passes Pig/YMC Resolution Print quality			4 passes YMC 1200x1200 Standard	6 passes YMC 1200x1200 High	

* Bold items are default settings

Table 2-5 Print Mode List (i950)

Paper type		Quality 5	Quality 4	Quality 3	Quality 2	Quality 1
Plain paper Post card Envelope	Passes Number of colors Resolution Print quality	1 pass 4 colors 1200x1200 Fast	2 passes 4 colors 2400x1200 Standard			8 passes 6 colors 2400x1200 ---
High resolution paper HR-101S	Passes Pig/YMC Resolution Print quality			4 passes 6 colors 2400x1200 ---	4 passes 6 colors 2400x1200 High	8 passes 6 colors 2400x1200 ---
Photo paper pro PR-101	Passes Pig/YMC Resolution Print quality				4 passes 6 colors 2400x1200 High	8 passes 6 colors 4800x1200 ---
Glossy photo paper GP-301	Passes Pig/YMC Resolution Print quality			4 passes 6 colors 2400x1200 Fast		8 passes 6 colors 2400x1200 High
Ink jet Post card	Passes Pig/YMC Resolution Print quality			4 passes 6 colors 2400x1200 Standard	4 passes 6 colors 2400x1200 High	8 passes 6 colors 4800x1200 ---
Glossy film HG-201	Passes Pig/YMC Resolution Print quality					8 passes 6 colors 2400x1200 High
T shirt transfer paper TR-201	Passes Pig/YMC Resolution Print quality			8 passes 4 colors 2400x1200 Standard		
OHP film CF-102	Passes Pig/YMC Resolution Print quality	4 passes 4 colors 2400x1200 Fast		8 passes 4 colors 2400x1200 Standard		
Matte photo paper MP-101	Passes Pig/YMC Resolution Print quality			4 passes 6 colors 2400x1200 Standard		8 passes 6 colors 2400x1200 High
Photo paper plus glossy PP-101	Passes Pig/YMC Resolution Print quality					8 passes 6 colors 4800x1200 High

* Bold items are default settings

4. FAQ

Table 2-6 PIXUS 550i/PIXUS 850i/PIXUS 950i Trouble

	Problems	Model	Cause	Action	Manual description
1	Paper moves diagonally/feed error	PIXUS550i PIXUS850i	When more print media is set, the separator roller slips causing skewed feeding or feed error.	Increase the strength of rubber material by changing it frequently in order to prevent pickup roller deformation. Schedule: End of Oct. 2002 (running change basis)	
2	Pinch roller marks (PR-101/GP-301)	PIXUS550i	The pinch roller oil adheres to the surface of the paper leaving pinch roller marks.	Left as is, as the problem is solved after 2 or 3 sheets of normal paper are fed.	
3	Spur marks (GP-301)	PIXUS550i	Spur and holder burrs cause marks.	Spur direction was changed, but faint spur marks remain. Left as is, as the spur mark is very faint.	
4	PR-101 Feed overlap occurs when multiple papers are stacked	All models	Static electricity between papers causes paper to stick together resulting in feed overlap.	Change specification in user manual to set up to 10 sheets of paper one at a time when stacking multiple sheets of paper.	Refer to User's Guide, Print Media, Photo Paper Pro PR-101
5	Head friction when printing on banner paper	All models	Banner paper is folded at the tip of the ejection tray causing it to buckle, affecting paper at the print area, resulting in head friction.	Change specification and description in user manual to perform banner printing with the ejection tray stored.	Refer to User's Guide, Print Media, Banner Paper
6	Ink mist	All models	Ink mists are generated during borderless paper printing and attaches to the platen rib.	(1) Change shape of platen rib (2) Control carriage overrun during L format borderless printing (3) Change default run over during borderless printing. Above three measures were taken, but ink mist could not be eliminated completely. Therefore, the platen rib is to be cleaned with a cotton swab on site when mists appear. Note: Do not touch the coat strip or borderless absorber.	
7	The final sheet of PR-101 paper moves diagonally	All models	Paper is skewed easily because of the single roller structure and the pressure of the side guide is strong when there is only one paper.	Set an extra sheet of plain paper under the last paper.	
8	Head friction	All models	(1) Paper float cannot be suppressed due to borderless printing support. (2) Head friction is caused by paper curl.	Set and print after correcting paper curl.	

Part 3
Appendix

1. Block Diagram

i550 Block Diagram

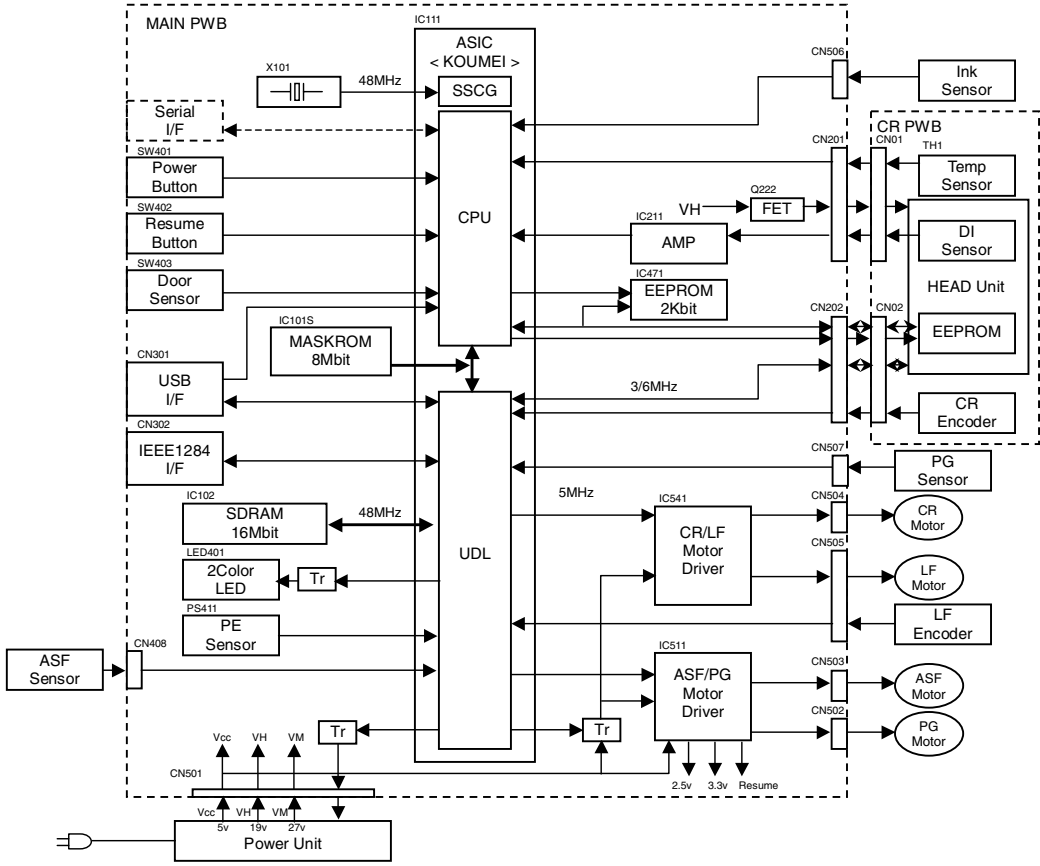

i850 Block Diagram

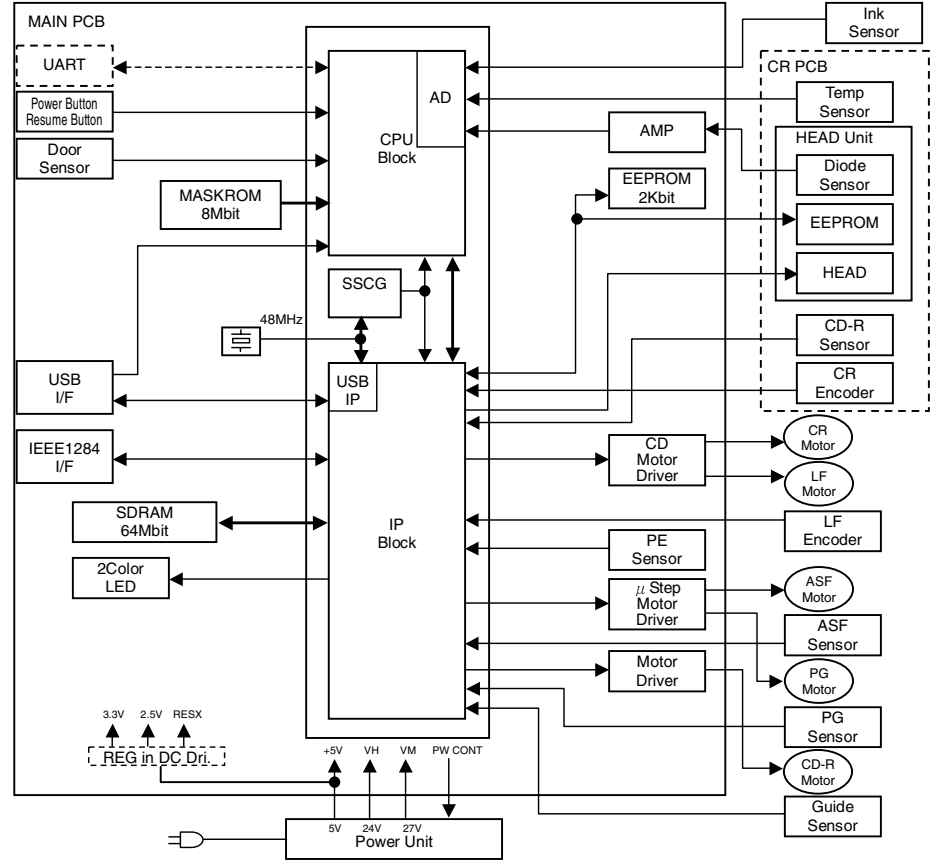

i950 Block Diagram

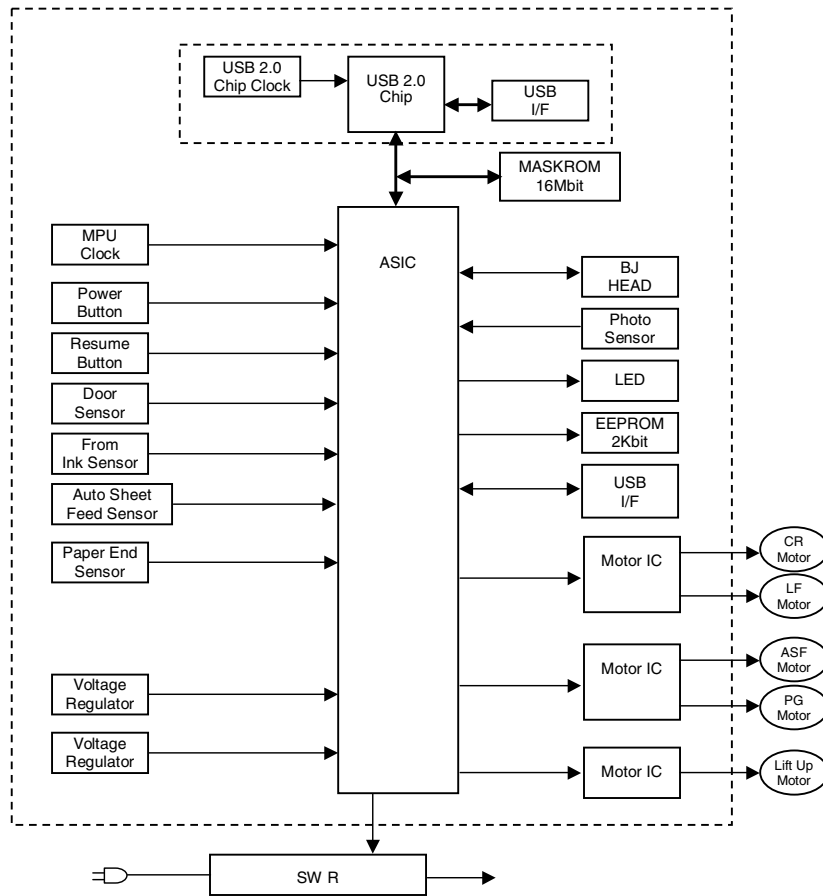

2. Connector Locations and Pin Layout

2.1 i550 Connector Location and Pin Layout

2.1.1 Logic board

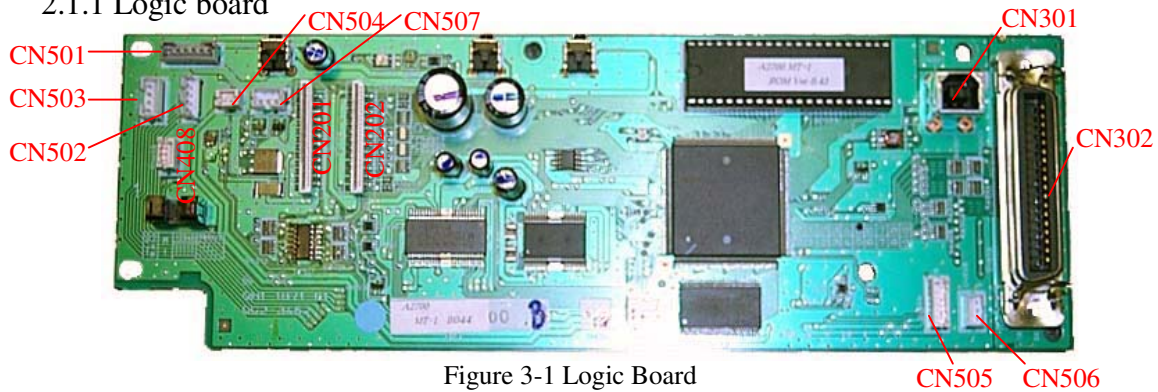

Figure 3-1 Logic Board

CN201 (Carriage ribbon cable connector)

Pin No.	Signal Name	Function
1	DIODE_GND	BK/COL diode sensor cathode
2	DIA1	COL diode sensor anode
3	DIK0	BK diode sensor anode
4	THERMO	Thermistor signal
5 - 6	HVDD	3.3V head logic power supply
7	HVSS	Logic GND
8	HVH	Head gate power supply
9 - 12	HVH	19V head (BK) power supply
13 - 16	HVH	19V head (COL) power supply
17 - 21	H_GND	Head (COL) GND
22 - 25	H_GND	Head (BK) GND

CN202 (Carriage ribbon cable connector)

Pin No.	Signal Name	Function
1	VSEN_3.3V	3.3 V power supply for encoder
2	CR_ENC0	Encoder signal phase A
3, 5, 9, 18, 22, 24	L_GND	Logic GND
4	CR_ENC1	Encoder signal phase B
6	H_ENB0	BK heat enable
7	H_ENB1	COL heat enable
8	H_ENB2	COL heat enable
10	H_D0	BK data
11	H_D1	BK data
12	H_D2	C data
13	H_D3	C data
14	H_D4	M data
15	H_D5	M data
16	H_D6	Y data
17	H_D7	Y data
19	H_EEPROM_DIO	Head EEPROM data
20	H_EEPROM_SK	Head EEPROM clock
21	H_EEPROM_CS	Head EEPROM chip select
23	H_CLK	Head data transfer clock
25	H_LATCH	Head data latch signal

CN301 (USB interface connector)

Pin No.	Signal Name	Function
1	USB_VBI	Cable power supply
2	USB_DN	Differential data signal
3	USB_DP	Differential data signal
4	GND	GND

CN302 (Parallel interface connector)

Pin No.	Compatible mode	Nibble mode	ECP mode
1	STROBE	HOST CLK	HOST CLK
2 - 9	DATA1 - 8	DATA1 - 8	DATA1 - 8
10	ACKNLG	PRT CLK	PRT CLK
11	BUSY	PRT BUSY	PRT BUSY
12	P.E.	ACK DATA REQ	ACK DATA REQ
13	SELECT	XFLAG	XFLAG
14	AUTO FEED XT	HOST BUSY	HOST BUSY
15	N.C	Undefined	Undefined
16, 17	GND	GND	GND
18	+5.0V	VCC	VCC
19	STROBE-RET(GND)	SIGNAL GND	SIGNAL GND
20	DATA1-RET(GND)	SIGNAL GND	SIGNAL GND
21	DATA2-RET(GND)	SIGNAL GND	SIGNAL GND
22	DATA3-RET(GND)	SIGNAL GND	SIGNAL GND
23	DATA4-RET(GND)	SIGNAL GND	SIGNAL GND
24	DATA5-RET(GND)	SIGNAL GND	SIGNAL GND
25	DATA6-RET(GND)	SIGNAL GND	SIGNAL GND
26	DATA7-RET(GND)	SIGNAL GND	SIGNAL GND
27	DATA8-RET(GND)	SIGNAL GND	SIGNAL GND
28	ACKNLG-RET	SIGNAL GND	SIGNAL GND
29	BUSY-RET	SIGNAL GND	SIGNAL GND
30	P.E.-RET	SIGNAL GND	SIGNAL GND
31	INIT	INIT	INIT
32	ERROR	DATA AVAIL	DATA AVAIL
33	GND	Undefined	Undefined
34	N.C	Undefined	Undefined
35	+5.0V	Undefined	Undefined
36	SELECT IN	1284 ACTIVE	1284 ACTIVE

CN408 (ASF sensor connector)

Pin No.	Signal Name	Function
1	VSEN_5V	ASF sensor power supply
2	GND	GND
3	SNS_ASF	ASF sensor output signal

CN501 (DC power supply connector)

Pin No.	Signal Name	Function
1	+5V	5V power supply
2, 4	GND	GND
3	VH	19V power supply
5	VM	27V power supply
6	PowerControl	Power consumption control signal

CN502 (Purge motor connector)

Pin No.	Signal Name	Function
1	PGA	PG motor phase A
2	PGB	PG motor phase B
3	PGAN	PG motor phase \bar{A}
4	PGBN	PG motor phase \bar{B}

CN503 (ASF motor connector)

Pin No.	Signal Name	Function
1	ASFA	ASF motor phase A
2	ASFB	ASF motor phase B
3	ASFAN	ASF motor phase \bar{A}
4	ASFBN	ASF motor phase \bar{B}

CN504 (Carriage motor connector)

Pin No.	Signal Name	Function
1	CRA	CR motor phase A
2	CRB	CR motor phase B

CN505 (Paper feed motor/LF encoder connector)

Pin No.	Signal Name	Function
1	LFA	LF motor phase A
2	LFB	LF motor phase B
3	GND	GND
4	LF_ENC0	LF encoder signal phase A
5	VSEN_3.3V	3.3 V power supply for encoder
6	LF_ENC1	LF encoder signal phase B

CN506 (Ink sensor connector)

Pin No.	Signal Name	Function
1	INK_5V	INK sensor power supply
2	GND	GND
3	INKS	INK sensor output signal

CN507 (Purge sensor connector)

Pin No.	Signal Name	Function
1	VSEN_5V	PG sensor power supply
2	GND	GND
3	SNS_PG	PG sensor output signal

2.1.2 Carriage board

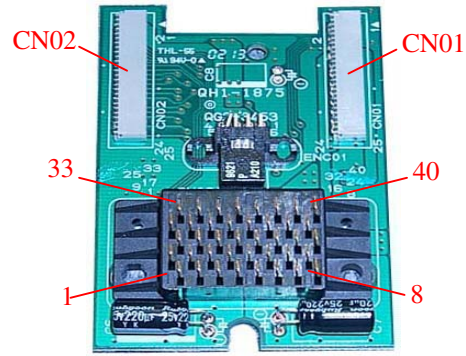

Figure 3-2 Carriage Board

CN01 (Carriage ribbon cable connector)

See Page 3-3 (CN201 Carriage ribbon cable connector)

CN02 (Carriage ribbon cable connector)

See Page 3-3 (CN202 Carriage ribbon cable connector)

CN03 (Print head contact)

Pin No.	Signal Name	Function
1 - 39		See page 3-7 (Print head pin description)

2.1.3 Print head



Figure 3-3 Print Head

Pin No.	Signal Name	Function
1, 2	A_GND	GND (black heater drive voltage)
3	H_D2	Cyan even column nozzle data signal
4	H_D6	Yellow even column nozzle data signal
5, 14, 22	B_GND	GND (color heater drive voltage)
6, 7, 8	DIK0	Head temperature sensor (diode) cathode side (black)
9	SUBH0	Black sub heater drive signal
10	H_D4	Magenta even column nozzle data signal
11	H_ENB1	Color nozzle heat enable signal (even/odd column odd no. block)
12	N.C	
13	H_D5	Magenta odd column nozzle data signal
15	DIK1	Head temperature sensor (diode) cathode side (color)
16	H_D0	Black even column nozzle data signal
17	H_ENB0	Black nozzle heat enable signal
18	N.C	
19	H_LATCH	Data latch enable signal
20	SUBH0	Color sub heater drive signal
21	H_D7	Yellow odd column nozzle data signal
23	H_ENB2	Color nozzle heat enable signal (even/odd column even no. block)
24	H_D1	Black odd column data signal
25	DIA0	Black
26	HVDD	Logic power supply
27, 35	H_EEPROM_CS	Head internal EEPROM chip select signal
28	H_CLK	Clock signal
29	E_D0	Head internal EEPROM output data signal
30	H_D3	Cyan odd column nozzle data signal
31	B_VH	Color heater drive voltage
32, 40	A_VH	Black heater drive voltage
33, 34	H_EEPROM_SK	Head internal EEPROM serial data clock signal
36	E_DI	Head internal EEPROM input data signal
37	DIA1	Head temperature sensor (diode) anode side (color)
38	VHT	Head internal power transistor drive power
39		

2.2 i850 Connector Location and Pin Layout

2.2.1 Logic board

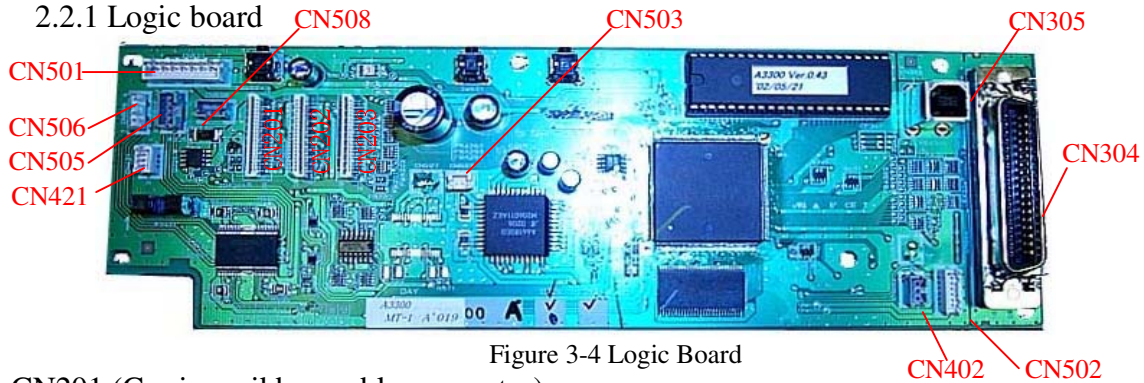

Figure 3-4 Logic Board

CN201 (Carriage ribbon cable connector)

Pin No.	Signal Name	Function
1 - 10	VH	24V head power supply
11 - 13	HVDD	3.3V head power supply
14, 19, 20	GND	Logic GND
15	H_ENB3	Heat enable 3
16	H_ENB0	Heat enable 0
17	H_ENB1	Heat enable 1
18	H_ENB2	Heat enable 2

CN202 (Carriage ribbon cable connector)

Pin No.	Signal Name	Function
1	DIA0	Diode sensor anode
2, 4, 9, 11	GND	Logic GND
3	THERMO	Thermistor
5,6	VSEN_3.3V	3.3V sensor power supply
7	CR_ENCA	Encoder signal phase A
8	CR_ENCB	Encoder signal phase B
10	SNS_CDR_P	CDR sensor signal
12 - 20	H_GND	Head GND

CN203 (Carriage ribbon cable connector)

Pin No.	Signal Name	Function
1 - 8	H_D0 - D7	Heat data
9 - 12	H_DS0 - DS3	Heat data
13	H_EEPROM_DIO	EEPROM data
14	H_EEPROM_SK	EEPROM clock
15	H_EEPROM_CS	EEPROM chip select
16, 19	GND	Logic ground
17	H_CLK	Head transfer clock
18	H_LATCH1	Latch signal
20	DIA1	Diode sensor anode

CN304 (Parallel interface connector)

See page 3-4 (CN302 Parallel Interface connector)

CN305 (USB interface connector)

See page 3-4 (CN301 USB Interface connector)

CN402 (Ink sensor connector)

Pin No.	Signal Name	Function
1	POW	Remaining ink sensor side power supply
2	GND	GND
3	INKS	Remaining ink sensor output

CN421 (ASF sensor connector)

Pin No.	Signal Name	Function
1	POW	ASF sensor illuminating side power
2	GND	GND
3	SNS_ASF	ASF sensor output

CN501 (DC power supply connector)

Pin No.	Signal Name	Function
1	+5V	GND
2, 4, 6	GND	
3	VH	
5	VMREM	
7	LOW_PW_CONT	Power consumption control

CN502 (Paper feed motor/LF encoder connector)

Pin No.	Signal Name	Function
1	LFA	LF motor phase A
2	LFB	LF motor phase B
3	GND	GND
4	LF_ENCA	LF encoder signal phase A
5	VSEN_3.3V	3.3 V power for encoder
6	LF_ENCB	LF encoder signal phase B

CN503 (Carriage motor connector)

Pin No.	Signal Name	Function
1	CRA	Carriage motor phase A
2	CRB	Carriage motor phase B

CN505 (ASF motor connector)

Pin No.	Signal Name	Function
1	ASFA	ASF motor phase A
2	ASFB	ASF motor phase B
3	ASF \bar{A}	ASF motor phase \bar{A}
4	ASFB	ASF motor phase B

CN506 (Purge motor connector)

Pin No.	Signal Name	Function
1	PGA	Purge motor phase A
2	PGB	Purge motor phase B
3	PG \bar{A}	Purge motor phase \bar{A}
4	PGB	Purge motor phase \bar{B}

CN508 (Purge sensor connector)

Pin No.	Signal Name	Function
1	POW	PG sensor illuminating side power supply
2	GND	GND
3	SNS_PG	PG sensor output

2.2.2 Carriage board

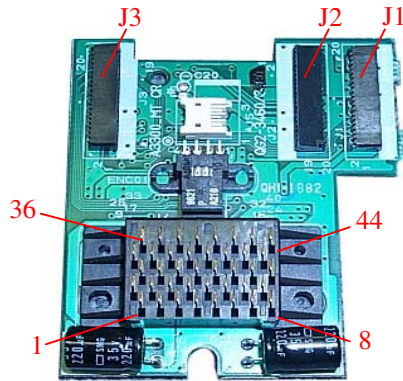

Figure 3-5 Carriage Board

J1 (Carriage ribbon cable connector)

See page 3-8 (CN201 Carriage ribbon cable connector pin description)

J2 (Carriage ribbon cable connector)

See page 3-8 (CN202 Carriage ribbon cable connector pin description)

J3 (Carriage ribbon cable connector)

See page 3-8 (CN203 Carriage ribbon cable connector pin description)

J4 (Print head)

Pin No.	Signal Name	Function
1 - 40		See page 3-11 (Print head pin description)

2.2.3 Print head

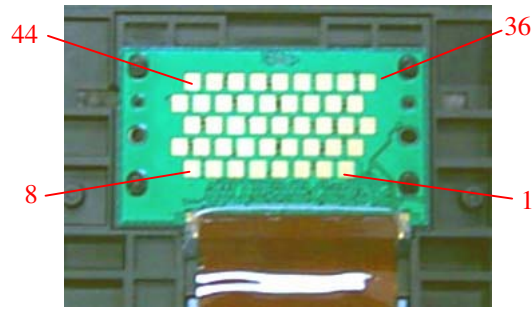

Figure 3-6 Print Head

Pin No.	Signal Name	Function
1, 2	A_GNDH	GND (black heater drive voltage)
3	B_DATA_C1	Cyan even column nozzle data signal
4	B_DATA_Y1	Yellow even column nozzle data signal
5, 14, 22	VSS	
6, 7, 8	B_GNDH	GND (color heater drive voltage)
9	B_DATA_C3	Cyan 2pl odd column nozzle data signal
10	B_DATA_M3	Magenta 2pl odd column nozzle data signal
11	B_DATA_M1	Magenta even column nozzle data signal
12	B_HE1	Color nozzle heat enable signal (even/odd column odd no. block)
13	B_DATA_M4	Magenta 2pl even column nozzle data signal
15	B_DATA_M2	Magenta odd column nozzle data signal
16	A/B_DIK	Head temperature sensor (diode) cathode side (color)
17	A_DATA_K1	Black even column nozzle data signal
18	A_HE	Black nozzle heat enable signal
19	B_HE3	2pl heat enable
20	LT	Data latch enable signal
21	B_DATA_C4	Cyan 2pl even column nozzle data signal
23	B_DATA_Y2	Yellow odd column nozzle data signal
24	B_HE2	Color nozzle heat enable signal (even/odd column even no. block)
25	A_DATA_K2	Black odd column data signal
26	A_DIA	Black
27, 35	VDD	Logic power supply
28	E_CS	Head internal EEPROM chip select signal
29	CLK	Clock signal
30	E_D0	Head internal EEPROM output data signal
31	B_DATA_C2	Cyan odd column nozzle data signal
32, 40	B_VH	Color heater drive voltage
33, 34	A_VH	Black heater drive voltage
36	E_SK	Head internal EEPROM serial data clock signal
37	E_DI	Head internal EEPROM input data signal
38	B_DIA1	Head temperature sensor (diode) anode side (color)
39	VHT	Head internal power transistor drive power supply
41	B_RANK	Not used
42	A_RANK	Not used
43	CONTB	Not used
44	CONTA	Not used

2.3 i950 Connector Location and Pin Layout

2.3.1 Logic board

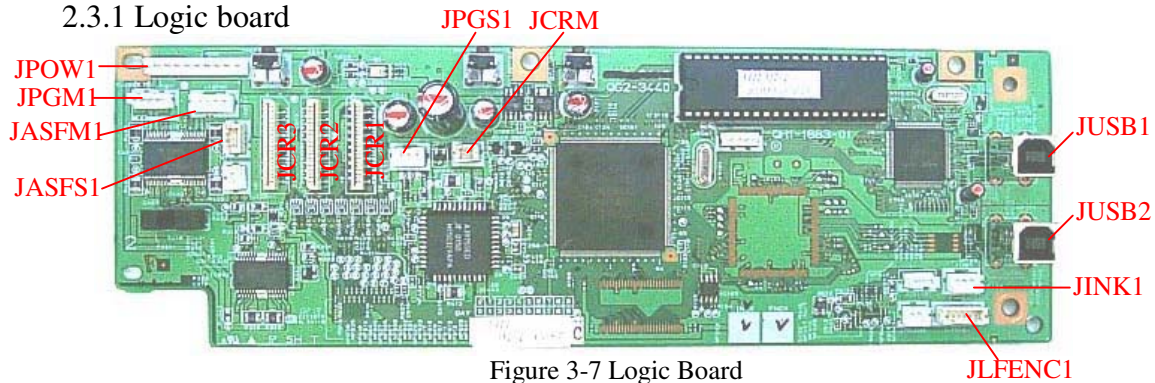

Figure 3-7 Logic Board

JCR1 (Carriage ribbon cable connector)

Pin No.	Signal Name	Function
1	AD_TH	Not used
2	CRENCA	Encoder signal phase A
3	EVDD	Sensor power supply
4	CRENCB	Encoder signal phase B
5	GND	GND
6	SE_CDREF	CDR sensor signal
7	GND	GND
8	HCLK	Head transfer clock
9	GND	GND
10	DATAK	K data
11	DHE	Dummy heater enable
12	HEEP_SK	Head EEPROM clock
13	BG	Transfer clock clutch signal
14	DATALC	LC data
15	HEEP_CS	Head EEPROM chip select
16	TSOCLC	C, LC status output
17	HECX	C heat enable
18	DATAC	C data
19	HELCX	LC heat enable
20	HEKX	K heat enable

JCR2 (Carriage ribbon cable connector)

Pin No.	Signal Name	Function
1 - 6	GND	GND
7	DATALM	LM data
8	TSOKY	K, Y status output
9	DATAY	Y data
10	HDSEN	Head sensor signal
11	HEEP_DI	Head EEPROM data
12 - 14	HVDD	Head power supply
15 - 20	VH	

JCR3 (Carriage ribbon cable connector)

Pin No.	Signal Name	Function
1 - 8	VH	
9	HEYX	Y heat enable
10	HELMX	LM heat enable
11	HEMX	M heat enable
12	DATAM	M data
13	TSOLMN	LM, M status output
14 - 20	GND	GND

JPOW1 (DC power supply connector)

Pin No.	Signal Name	Function
1, 2	VH	
3	VM	
4, 5	GND	GND
6	5V	
7	GND	
8	VHREM	VH output enable
9	VMREM	VM output enable

JPGS1 (Purge sensor connector)

Pin No.	Signal Name	Function
1	POW	Power supply
2	GND	GND
3	SNS_PG	PG sensor output

JINK1 (Ink sensor connector)

Pin No.	Signal Name	Function
1	POW	Power supply
2	GND	GND
3	AD_INK	Remaining ink sensor output

JASFM1 (ASF motor connector)

Pin No.	Signal Name	Function
1	ASFA	ASF motor phase A
2	ASFB	ASF motor phase B
3	ASF \bar{A}	ASF motor phase \bar{A}
4	ASF \bar{B}	ASF motor phase \bar{B}

JPGM1 (Purge motor connector)

Pin No.	Signal Name	Function
1	PGA	PG motor phase A
2	PGB	PG motor phase B
3	PG \bar{A}	PG motor phase \bar{A}
4	PG \bar{B}	PG motor phase \bar{B}

JASFS1 (ASF sensor connector)

Pin No.	Signal Name	Function
1	POW	Power supply
2	GND	GND
3	SNS_ASF	ASF sensor output

JLFENC1 (Paper feed motor/LF encoder connector)

Pin No.	Signal Name	Function
1	LFA	LF motor phase A
2	LFB	LF motor phase B
3	GND	GND
4	LF_ENCA	Encoder signal phase A
5	EVDD	Sensor power supply
6	LF_ENCB	Encoder signal phase B

JUSB2 (USB interface connector)

Pin No.	Signal Name	Function
1	USB_VBI	Cable power supply
2	USB_DM	Differential data signal
3	USB_DP	Differential data signal
4	GND	GND

JCRM1 (Carriage motor connector)

Pin No.	Signal Name	Function
1	CRA	CR motor phase A
2	CRB	CR motor phase B

2.3.2 Carriage board

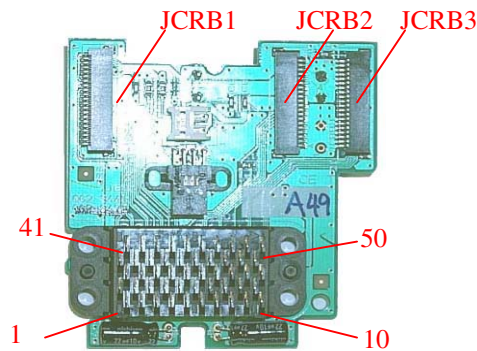

Figure 3-8 Carriage Board

JCRB1 (Carriage ribbon cable connector)

See page 3-12 (JCR1 Carriage ribbon cable connector pin description)

JCRB2 (Carriage ribbon cable connector)

See page 3-12 (JCR2 Carriage ribbon cable connector pin description)

JCRB3 (Carriage ribbon cable connector)

See page 3-13 (JCR3 Carriage ribbon cable connector pin description)

JHD1 (Print head contact)

Pin No.	Signal Name	Function
1 - 50		See page 3-15 (Print head pin description)

2.3.3 Print head

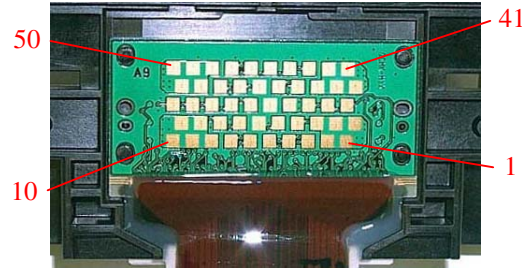

Figure 3-9 Print Head

Pin No.	Signal Name	Function
1, 2, 8 - 13	GNDH	Head GND
19, 20	GNDH	Head GND
3	DATA C	C DATA
4	DATA LC	LC DATA
5	DATA LK	LK DATA
6	DATA Y	Y DATA
7	DATA LM	LM DATA
14	TSOCLC	C, LC status output
15	BG	Transfer clock clutch signal
16	H DSEN	Head sensor signal
17	H CLK	Head transfer clock
18	DATA M	M DATA
21	HE LKX	LK heat enable
22	HE LCX	LC heat enable
23	HE CX	C heat enable
24	3.3V	Logic 3.3V
25, 36	GND	GND
26	VSS- A	
27	VDD- A	
28	HE M X	M heat enable
29	HE LM X	LM heat enable
30	HE Y X	Y heat enable
31 - 33, 39 - 42	VH	16V head power supply
48 - 50	VH	16V head power supply
34	3.3V	Logic 3.3V
35	DHE	Dummy nozzle drive signal
37	TSOLMC	LM, C status output
38	TSOLMM	LM, M status output
43	E_CS	Head EEPROM chip select
44	E_SK	Head EEPROM clock signal
45	E_DI	Head EEPROM data signal
46	E_DO	Head EEPROM data signal
47	VHT	Short with VH on logic board

2.4 i550 / i850 Printer Specifications

<Printer Specifications>

Type	Desktop serial color bubble jet printer					
Paper feeding method	Auto sheet feed (no manual sheet feed)					
Resolution (Max.)	i550: 2400dpi x 1200dpi / i850: 4,800 dpi x 1,200 dpi					
Throughput	i550	HS mode	HQ mode	i850	HS mode	HQ mode
	Black:	18 ppm	13 ppm		22 ppm	13 ppm
	Color:	11 ppm	7 ppm		14 ppm	10 ppm
Printing direction (Plain paper / Specialty paper)	i550/ i850 bi-directional					
Print width	Max. 203 mm (8 inches) For borderless printing, please see 2-2, "Print Media Specifications."					
Interface	IEEE1284 compatible (bidirectional parallel) USB2.0 (FullSpeed) compatible					
ASF stacking capacity	Plain paper (64 g / m ²): Max. 13 mm (Approx. 150 sheets)					
Detection functions	- Cover open - Waste ink amount - Paper out - Internal ambient temperature			- Presence of BJ cartridge - Ink out - Head-to-paper distance - Print media size		
Noise (during printing)		HQ mode	Fine mode			
	i550	46dB(A)	39dB(A)	Complaint with sound pressure level ISO9296		
	i850	46dB(A)	37dB(A)	Complaint with sound pressure level ISO9296		
Environmental requirements	During operation	Temperature	5C to 35C (41F to 95F)			
		Humidity	10%RH to 90%RH (no condensation)			
	Non operation	Temperature	0C to 40C (32F to 104F)			
		Humidity	5%RH to 95%RH (no condensation)			
Power supply	Input voltage	Frequency	Power consumption	Standby	Power-off	
	i550					
	AC 100 to 127V	50 / 60Hz	Approx. 24W (max.)	Approx. 0.7W	Approx. 0.3W	
	AC 220 to 240V	50 / 60Hz	Approx. 24W (max.)	Approx. 0.7W	Approx. 0.3W	
	i850					
	AC 100 to 127V	50 / 60Hz	Approx. 24W (max.)	Approx. 0.7W	Approx. 0.4W	
	AC 220 to 240V	50 / 60Hz	Approx. 24W (max.)	Approx. 0.7W	Approx. 0.4W	
External dimensions	Approx. 418 mm (W) x 274 mm (D) x 159 mm (H)					
Weight	Approx. 5 kg, not including print head					
Related standards (Printer, Adapter)	Electromagnetic radiance: VCCI, FCC, IC, C-tick, Taiwan EMC, Korea EMC, CCIB (EMC), Gost-R,CEMark Electrical safety: Electrical Appliance and Material Control Law (DENTORI), UL, Cul, CE Mark GS, FIMKO, SASO, AS, PSB, CB Report, CCIB, SBC, IRAM, Electrical Safety Regulations of Korea Environmental regulations: Energy Star, Blue Angel, Environment label					
Serial number location	On the carriage ribbon cable holder (visible when the front cover is open).					

<Print Head Specifications>

	i550 print head: QY6-0045	i850 print head: QY6-0042
Type	Replaceable ink tank type, single head for black and color (YMC) ink tanks	
Print head	BK: 320 nozzles in 2 vertical lines CL: 256 nozzles in 2 vertical lines per color	BK: 320 nozzles in 2 vertical lines CL: 512 nozzles in 4 vertical lines per color for magenta and cyan 256 nozzles in 2 vertical lines for yellow
Ink color	Pigment-based black, Dye-based cyan, magenta, yellow	
Ink tank	BCI-3eBK , BCI-3eC, BCI-3eM, , BCI-3eY	
Weight	BK:32g C/M/Y:11g	

i950 Printer Specifications

<Printer Specifications>

Type	Desktop-type serial printer		
Paper feeding method	Auto sheet feed		
Resolution	4,800 x 1,200 dpi (max.)		
Throughput speed (Target value)		HS	HQ
	Bk (Fast Gear)	7 ppm	4 ppm
	Color (Fast Gear)	7 ppm	4 ppm
	Photo	-	1 ppm
Printing direction	Bi-directional / Uni-directional		
Print width	203 mm (216 mm at borderless printing)		
Interface	USB2.0 Full Speed		
ASF stacking capacity	Max. 13 mm (Approx. 130 pages of 75 g/m ²)		
Detection functions	Cover open:	Available	
	Presence of print head:	Available	
	Paper out:	Available	
	Waste ink full:	Available	
	Paper width:	Not available	
	Remaining ink amount:	Available (optical and dot-count methods)	
Head alignment	Available (even/uneven nozzles in each color, and bi-directional registration)		
Acoustic noise level	37dB (at highest print quality)		
Environmental requirements	During operation	Temperature	5°C to 35°C (41°F to 95°F)
		Humidity	10% to 90% (no condensation)
	Non-operation	Temperature	0°C to 40°C (32°F to 104°F)
		Humidity	5% to 95% (no condensation)
Power supply	Power voltage / Frequency, Power consumption, Stand-by, Power-off		
	AC100V-127V / 50/60Hz	Approx. 24W (max.)	Approx. 2W
	AC220V-240V / 50Hz	Approx. 24W (max.)	Approx. 2W
External dimensions	418 (W) x 274 (D) x 160 (H) mm		
Weight	5.0 kg (excluding the print head)		
Related standards	RFI: VCCI, FCC, IC, CE Mark, Taiwan EMC, CCIB (China EMC), C-tick, Gost-R Electrical safety: Safety standard (Japan), UL, C-UL, CB Report, GS, CE Mark, FIMCO, CCIB, AS, CCEE, PSB, Korean safety standard, SASO, SBC (Brasil), IRAM (Argentina) Environment-related standards: Blue Angel, Energy Star, Environment label, Printer Eco-label		
Serial No. location	Carriage ribbon cable holder (visible with front cover open)		

<Print Head Specifications>

Structure:	6-color integrated type, ink tank separate type
Print head:	512 x 6 nozzles, 1,200 dpi pitch, 2pl ink droplet
Ink colors:	Bk, C, M, Y, C photo, M photo
Weight:	Approx. 70g (excluding ink tanks)
Supply method:	Service part (excluding ink tanks)
Part number:	QY6-0043-000

Note: Order of ink tanks installed is different from that of other models which use the BCI-6 ink tanks.

CANON INC.